

Heavy Duty Floor Grilles

Model

CFLG - B

Overview

The CFLG-B is a traditional format floor grille, which has been updated using a new reinforcing extrusion. This enables our grille to be lighter yet stronger, bringing it into line with today's exacting standards, while making installation easier. The CFLG-B is fully certified to heavy grade standard.

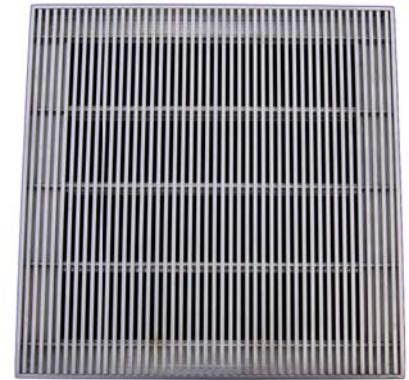

Construction

- Extruded aluminium frame and 6.00mm wide blades.
- Manufactured using self tapping screws.
- Expanded and reinforced core.

Options and accessories

Please see our list of options and accessories below for an overview of what we can do.

- **Opposed blade damper** - Aluminium OBD, operated via key/screwdriver, access possible through blades. Please note that this is not a shut off damper and only enables balancing of the air system.
- **Blanking plate** - Blanking plates enable a portion or all of the grille to be disabled. For instance if aesthetics demand that there be a row of grilles, yet only half will be used for air movement, the other half can be blanked to accommodate this.
- **Feet** - Feet of any size can be fitted to computer room floor grilles. These enable the grille to be mounted flush to whatever floor tile is being fitted around it.

Technical information

- Free area - Approx 33%
- CFLG-B - 600 x 600 O/A Mass - 11.25 KG
- CFLG-B/D - 600 x 600 O/A Mass - 13.00 KG
- 600 x 600 O/A - CFLG-B

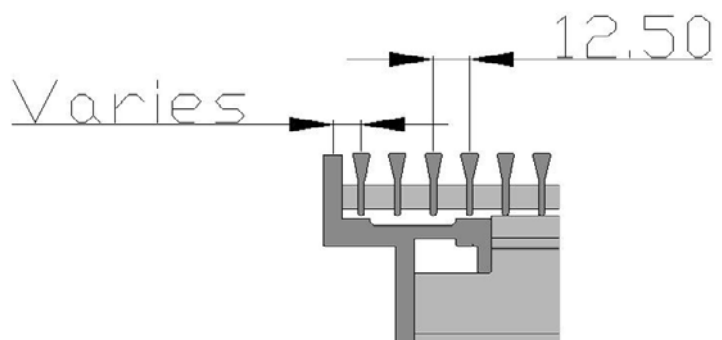
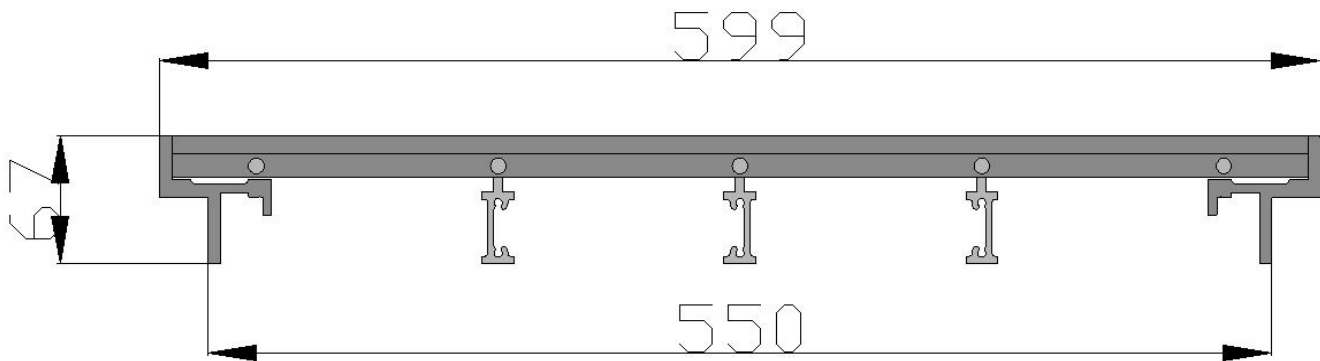
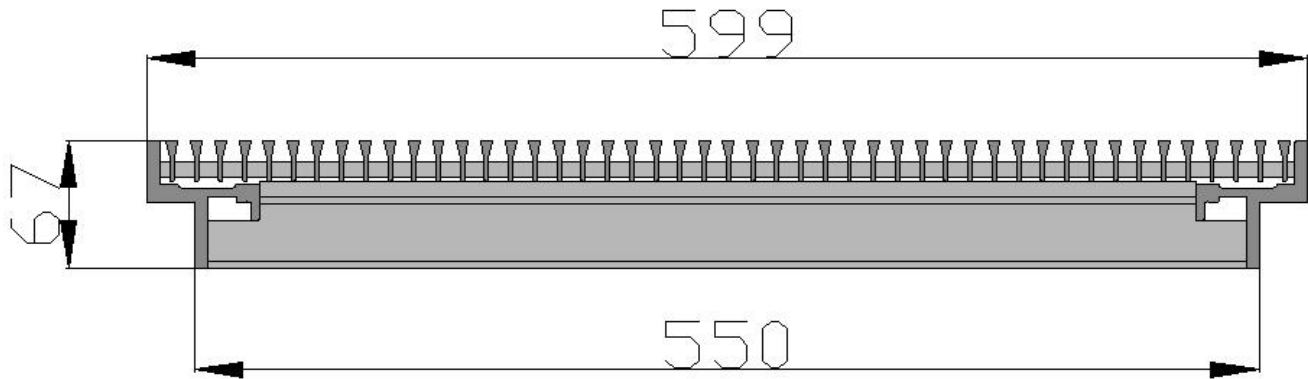

Distance between outermost blade and frame is variable based on size. On a standard 600 x 600 O/A this gap is approximately 2.00mm.

All dimensions are in mm.

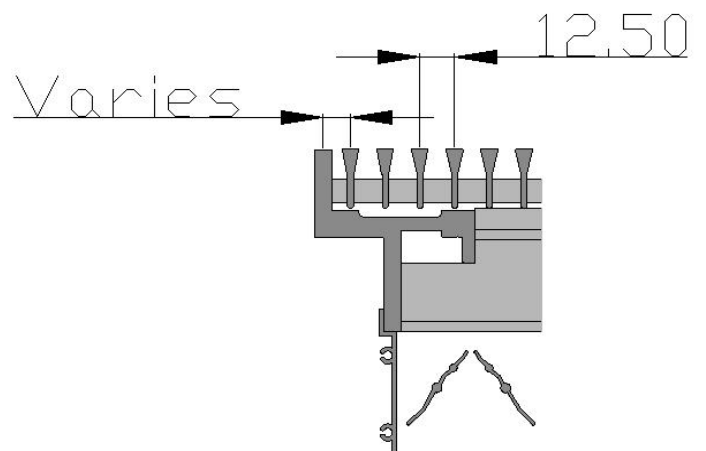
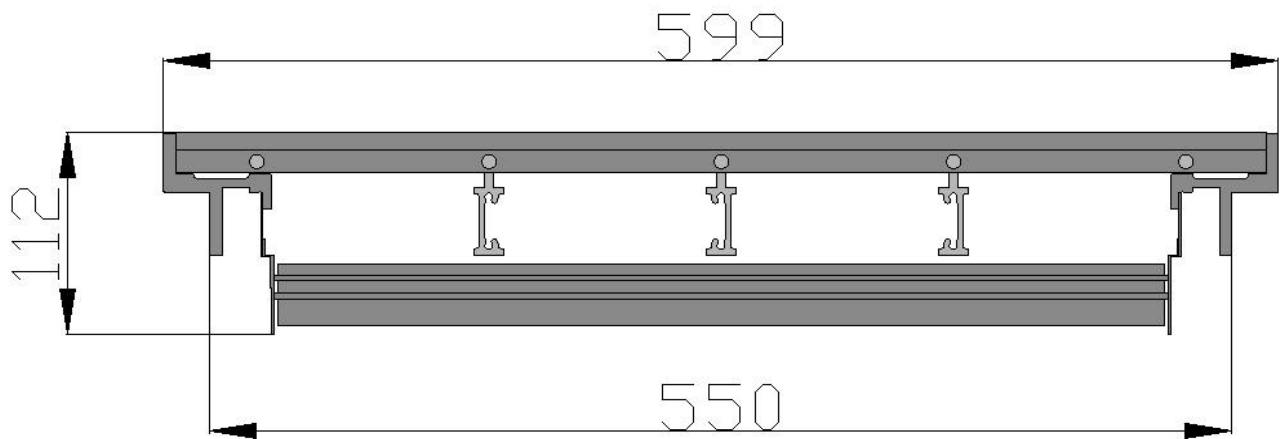
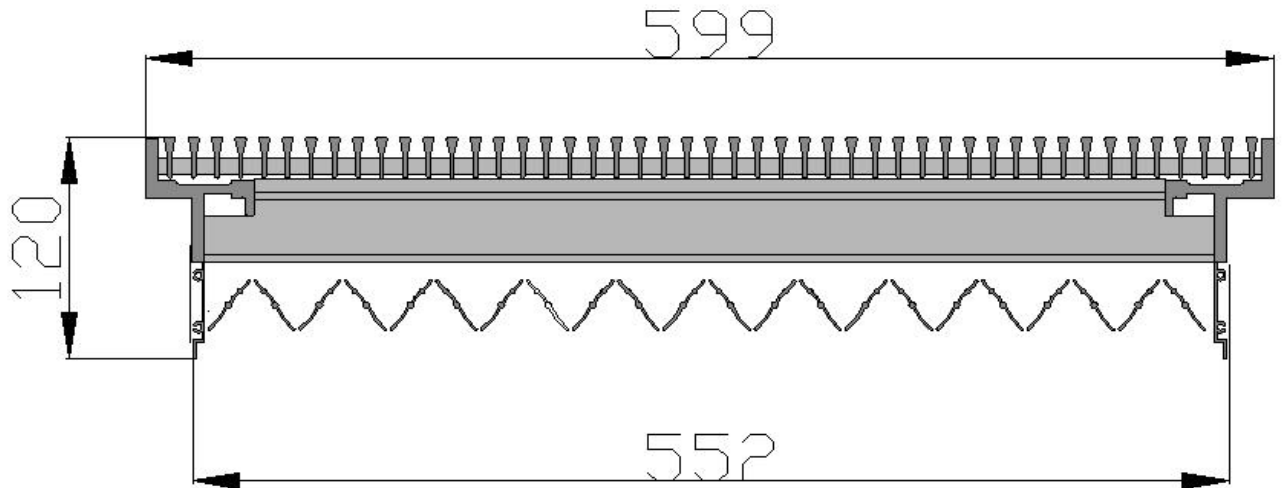

Distance between outermost blade and frame is variable based on size. On a standard 600 x 600 O/A this gap is approximately 2.00mm.

All dimensions are in mm.

The CFLG-B floor grilles are suitable for all raised access flooring types and are also fully compatible with stringers.

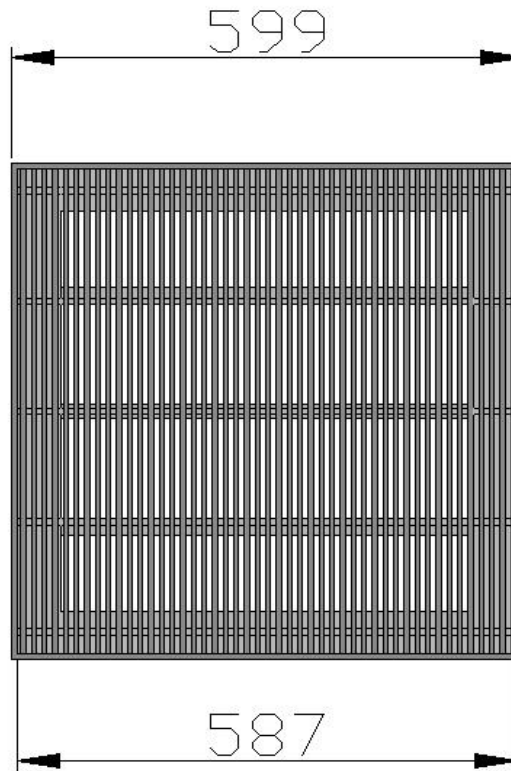

Grille Size - 600 x 600 Overall		Air Volume M ³ /S						
		0.20	0.25	0.35	0.45	0.55	0.75	0.90
SUPPLY	Noise (NR)	21	21	22	23	24	25	
	Throw (m)	3	3.50	4	4.50	5	6	
	Pressure Drop (Pa)	2	2.50	3.50	5.50	7.50	12	
EXTRACT	Noise (NR)	21	22	25	27	29	33	35
	Pressure Drop (Pa)	3	5	7	10	14	24	33

- NR ratings are based on dampers fitted in fully open position.
- Increase pressure drops where dampers are fitted by 50%.
- Do not exceed 1m³/s volume, or 2.5m/s face velocity per 600 x 600 unit.

All dimensions are in mm.

Certification

CFLG-B floor grilles are fully certified to BS EN 13264:2001 - heavy grade floor grilles.

The test was conducted on the 9th of March 2009 at the CERAM facility in Stoke on Trent. Full copies of the test certificate are available on request.

Installation

All CFLG-B floor grilles are designed to be laid into a prepared raised access floor, therefore installation simply involves laying the grille into position.

The feet are installed to raise the floor grille to be level with the raised access floor system.

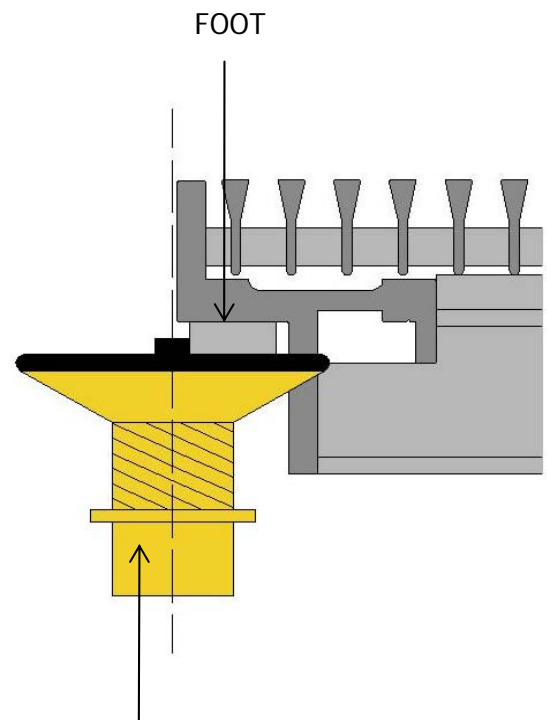

TOP SECTION OF PEDESTAL

Ordering Codes

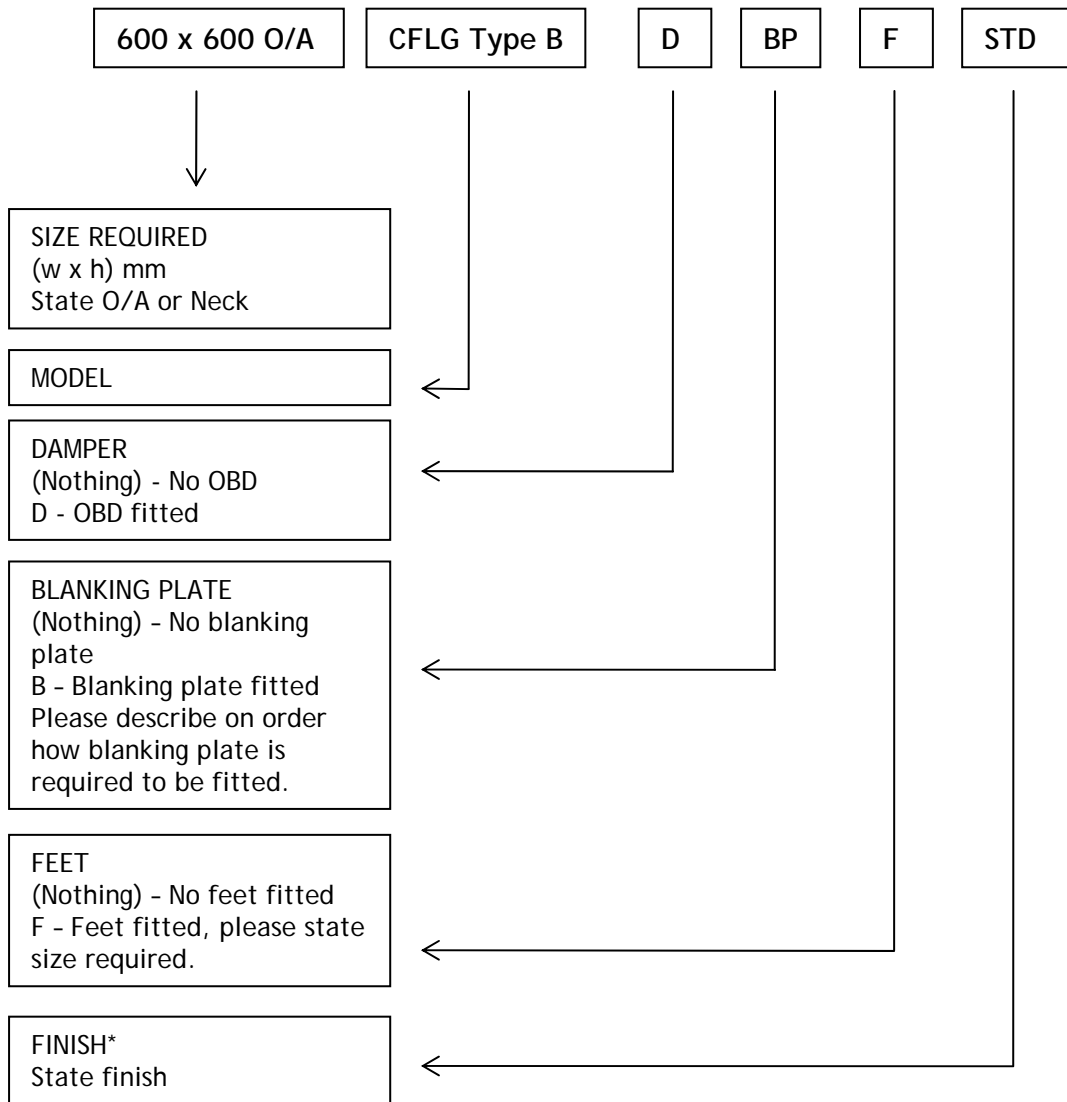

* Standard finish on a CFLG-B is Linished. Nylon coated and Polyester powder coated are available as alternative finishes.